

## Help Line

Australia	+1-800-33-11-77
Canada	+1-800-665-4339
México	+1-800-234-1185
United States	+1-800-955-0959

## Fellowes

Australia	+61-3-8336-97000
Benelux	+31-(0)-76-523-2090
Canada	+ 1-905-475-6320
Deutschland	+ 49-(0)-5131-49770
France	+ 33-(0)-1-30-06-86-80
Italia	+ 39-071-730041
Japan	+ 81-(0)-3-5496-2401
Korea	+ 82-(0)-2-3462-2884
Malaysia	+ 60-(0)-35122-1231
Polska	+ 48-(22)-771-47-40
Spain	+ 34-91-748-05-01
Singapore	+(65)-6221-3811
United Kingdom	+ 44-(0)-1302-836836
United States	+ 1-630-893-1600



DM12C

Please read these instructions before use  
Veuillez lire ce Mode d'emploi avant utilisation  
Por favor, lea estas instrucciones antes del uso

**Fellowes** 1789 Norwood Avenue, Itasca, Illinois 60143-1095 • USA • 630-893-1600

<http://www.fellowes.com>

Australia	Canada	Deutschland	France	Japan	Polska	United Kingdom
Benelux	China	España	Italia	Korea	Singapore	United States

©2006 Fellowes, Inc. Form No. 401498

ENGLISH

FRANÇAIS

ESPAÑOL

**Get More Done Today™**

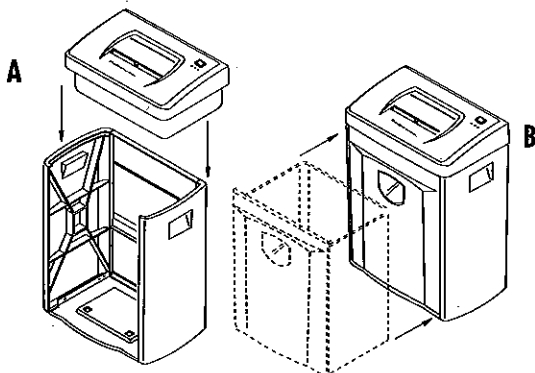
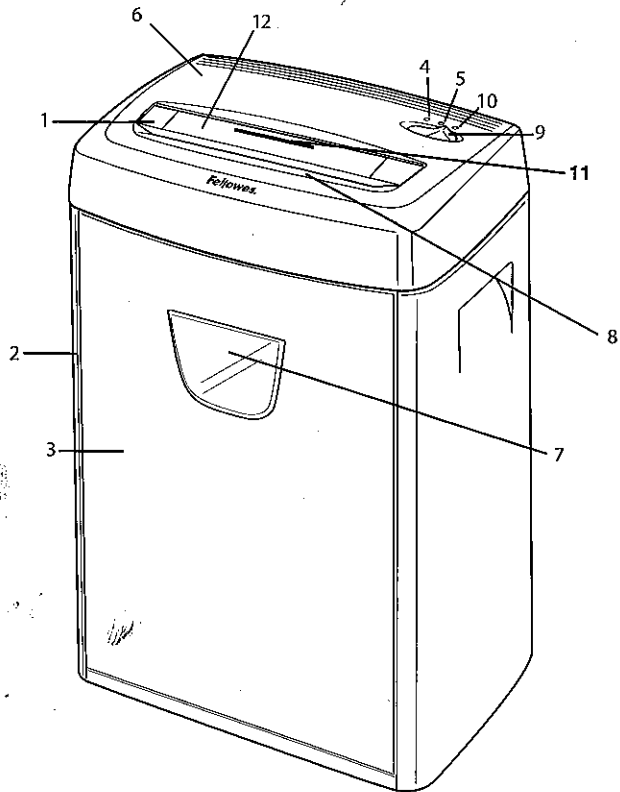

## Fellowes

Dear Customer,

Thank you for buying a Fellowes Personal Shredder. We have made many improvements in our personal shredder since its introduction in 1990 as the first of its kind on the market. We are confident that it offers you the greatest value for your money in its product category today. We hope it meets – or even exceeds – your expectations.

To ensure years of safe, efficient use, please read these few pages about your new shredder. If this manual doesn't answer all your questions or if you wish to comment on this product, we welcome your call or letter.

Sincerely,

James Fellowes  
CEO

## Contents

Product Profile .....	3
Important Safety Instructions .....	3
Set-Up .....	4
Operation .....	4
Maintenance .....	5
Troubleshooting .....	5
Limited Warranty .....	6



## Product Profile

This product is built to shred **paper, staples, small paper clips, credit cards, CDs and DVDs** (CDs and DVDs in designated slot). It is *not* built to shred transparencies, adhesive labels, newspaper, cardboard, large paper clips, or plastic (other than items noted above). Attempting to shred items not intended for this shredder may cause damage.

### Confetti-cut (DM12C)

Paper	
Sheet capacity*	12 sheets
Paper shred size	5/32" x 1-3/8" (3.9 x 35 mm)
Maximum paper width	9" (229 mm)
Speed (at paper capacity)	14 ft/min
Maximum running time (duty cycle on)	20 minutes
Automatic cool-down period	40 minutes
Recommended daily capacity	25-50 shredding passes
Credit Cards	
Credit card capacity	1
Recommended daily capacity	10
CDs/DVDs	
CDs/DVDs capacity	1
Recommended daily capacity	10

\*Based on 8-1/2 x 11" (75 g/20 lb.) paper with shredder operating at rated voltage; heavier paper, high humidity, or other than rated voltage may reduce sheet capacity.

**NOTE:** These products have met **international standards** for motor temperature rise: Independent product testing agencies approved each model at the midpoint of its sheet-per-pass limit. In the tests, the agencies also varied the available voltage 10% below and 6% above its normal range, stopping shredding only to empty the basket.

## ⚠ IMPORTANT SAFETY INSTRUCTIONS READ ALL INSTRUCTIONS BEFORE USING

### While assembling shredder

- Check shredder for damage or defects; some paper particles in the basket are normal due to product testing and does not indicate a defect.
- If the cord is damaged do not replace cord or use the machine. Return machine for a replacement.
- Avoid touching exposed blades on underside of confetti-cut shredder head.
- Plug power cord in an outlet that can easily be reached.
- Do not place shredder near or over a heat or water source.

### While operating shredder

- Keep hands and hanging objects (jewelry, ties, loose clothing, long hair, etc.) away from paper entry.
- Keep children and pets away from the shredder.



### When not in use

- Always turn off and unplug shredder
- Unplug before emptying basket
- Do not open shredder head: Danger of electric shock.



**NOTE:** Do not use flammable synthetic oil, petroleum-based products or aerosols of any kind on or near product at any time.



## Set-Up

For safety reasons, this model will operate only if the shredder head (6) is in the correct position on the cabinet (2) and used with supplied basket (3).

- Position shredder head over cabinet. Place shredder head on top of cabinet as shown in *Figure A*.
- Firmly push down on four corners of shredder head to "lock" shredder head into position.
- Push basket into shredder cabinet as shown in *Figure B*.

**Notes:** To disassemble, pull out basket, hold cabinet down by placing foot on bottom shelf, and firmly pull up on shredder head.

## Operation

For convenience, your shredder is equipped with an **automatic-start sensor (8)**. This means that when the control switch (9) is in the automatic [I] position, the shredder will start running when you put paper into it and stop a few seconds after the paper has passed through. Because the sensor cannot tell the difference between paper and other objects, this feature can also be a hazard, especially to children and pets. To avoid accidents, turn off the shredder as soon as you are finished. Unplug shredder if it will not be used for an extended period.

### To shred

- Press control switch (9) to automatic [I] position. Green ready light (4) should turn on.

#### PAPER

- Feed paper straight into entry (1), releasing when shredder begins shredding; see *Product Profile* for limits on paper width, shreddable items, sheet capacity, etc.
- Shred no more than 20 minutes; shredding longer will cause shredder to turn itself off for 40 minutes to cool down.
- Press control switch to off [O] position after cutting has stopped.

#### CDs, or DVDs

- Slide safety cover (12) to the front to expose the CD entry (11).
- Hold CD or DVD at the edge and feed one at a time, straight into entry (11) releasing when shredding begins. Shredder will stop when item has passed through entry. CDs and DVDs will be shredded into small particles.
- Slide cover (12) to the back when done shredding media.

**CAUTION:** Do not hold CD or DVD with finger through the center ring while feeding into shredder.

In case of a **paper jam**, which may occur if the shredder is pushed beyond its specified capabilities, press the control switch to the off [O] position and empty the basket if full. Then:

- 1) Press and hold control switch in reverse [R] position and attempt to back paper out of shredder.
- 2) If shredder jams in reverse mode, press control switch to automatic [I] position and attempt to continue shredding operation.
- 3) If shredder jams again, alternate control switch slowly between reverse [R] and automatic [I] positions to attempt to move jammed paper completely through shredder.

If you are unable to clear the jam using this method, turn off and unplug the shredder; remove the wastebasket from cabinet and carefully remove any paper extending below the cutting cylinders; empty the wastebasket; insert wastebasket and repeat jam clearing procedure.

## Maintenance

**Regular emptying of the basket** is important to ensure the smooth operation of the cutting cylinders. If you can see paper in the basket window (7), turn off the shredder, pull out the basket and empty basket contents.

**Regular oiling of the shredder** is also necessary to ensure proper performance. If you are running the shredder at or near capacity, we recommend oiling it *monthly*. Using Fellowes Powershred Lubricant #35250 or other non-aerosol vegetable-based oil in a long-nozzle container:

- Apply oil over full width of paper entry (1) with shredder in off [O] position.
- Press control switch to automatic [I] position which will cause shredder to run for about 2 seconds.
- Press and hold control switch in reverse [R] position for 3-5 seconds.
- Repeat above automatic [I] and reverse [R] sequence three times.



**REMEMINDER:** Do not use flammable synthetic oil, petroleum-based products or aerosol lubricants of any kind in or near the shredder at any time.



## Troubleshooting

If you have a problem with your shredder, check the symptoms and remedies below. If you cannot solve the problem this way, contact Fellowes Customer Service. **Do not open shredder head to attempt repair:** It could expose you to serious electric shock and will void your warranty.

Symptom	Remedy
Shredder does not start or stops while shredding.	<ul style="list-style-type: none"> <li>• Make sure shredder is plugged in and switch is in automatic [I] position.</li> <li>• If paper appears to be jammed. Follow instructions under <i>Operation</i>.</li> <li>• Check basket position; basket must be pushed all the way in the cabinet. Follow instructions under <i>SetUp</i>.</li> </ul>
Overheat light (10) turns on and shredder will not operate.	<ul style="list-style-type: none"> <li>• Wait 40 minutes for shredder to cool down before trying again.</li> </ul>
Red display light (5) turns on and shredder will not operate.	<ul style="list-style-type: none"> <li>• If paper appears to be jammed. Follow instructions under <i>Operation</i>.</li> <li>• Check basket position; basket must be pushed all the way in the cabinet. Follow instructions under <i>SetUp</i>.</li> </ul>
Shredder squeaks, grinds or runs below capacity.	<ul style="list-style-type: none"> <li>• Oil cutting cylinders. Follow instructions under <i>Maintenance</i>.</li> </ul>
Shredder continues to run for a few seconds after shredding has been completed.	<ul style="list-style-type: none"> <li>• No action required. This is a self-cleaning function.</li> </ul>

## Limited Warranty

Fellowes, Inc. warrants the cutting cylinders of the machine to be free from defects in material and workmanship for **5 years** from the date of purchase by the original consumer. Fellowes warrants all other parts of the machine to be free of defects in material and workmanship for **1 year** from the date of purchase by the original consumer. If any part is found to be defective during the warranty period, your sole and exclusive remedy will be repair or replacement, at Fellowes' option and expense, of the defective part.

This warranty does not apply in cases of abuse, mishandling or unauthorized repair. ANY IMPLIED WARRANTY, INCLUDING THAT OF MERCHANTABILITY OR FITNESS FOR A PARTICULAR PURPOSE, IS HEREBY LIMITED IN DURATION TO THE APPROPRIATE WARRANTY PERIOD SET FORTH ABOVE. IN NO EVENT SHALL FELLOWES BE LIABLE FOR ANY CONSEQUENTIAL OR INCIDENTAL DAMAGES ATTRIBUTABLE TO THIS PRODUCT. This warranty gives you specific legal rights.

You may have other legal rights that vary from this warranty. The duration, terms and conditions of this warranty are valid worldwide, except where different limitations, restrictions or conditions may be required by local law.

To obtain service under this warranty, please contact us (see back cover) or your dealer.

## Fellowes

*Cher client,*

*Nous vous remercions d'avoir acheté un destructeur de documents personnel Fellowes. Nous avons considérablement amélioré notre modèle personnel de destructeur de documents depuis son introduction en 1990 comme le premier du genre. Nous ne doutons pas qu'il vous offre le meilleur rapport qualité-prix de sa catégorie aujourd'hui. Nous espérons qu'il répondra – ou même dépassera – vos attentes.*

*Pour assurer des années d'utilisation sûre et efficace, veuillez lire ces quelques pages sur votre nouveau destructeur de documents. Si ce manuel ne répond pas à toutes vos questions ou si vous voulez faire des commentaires sur ce produit, n'hésitez pas à nous contacter.*

*Sincèrement,*

*James Fellowes  
Président-directeur général*

## Table des matières

Profil du produit .....	8
Consignes de sécurité importantes .....	8
Installation .....	9
Fonctionnement .....	9
Entretien .....	10
Dépannage .....	10
Garantie limitée .....	11